

Patents: why do they hinder innovation?

Dr. George Dafermos

FLOK Society Project *Instituto de Altos Estudios Nacionales (IAEN)*

[*def.*] A patent is a set of exclusive rights granted by a sovereign state to an inventor of a new method, substance or mechanism. This exclusive right is granted for a limited time period (e.g. 20 years) following the submission of the patent application and forbids others to use the patented method, substance or mechanism without the permission of the patent owner.

“A patent does not give a right to make or use or sell an invention. Rather, a patent provides the *right to exclude others* from making, using, selling, offering for sale, or importing the patented invention for the term of the patent, which is usually 20 years from the filing date”.

Source: <<http://en.wikipedia.org/wiki/Patent>>



Certificate of Grant of Patent

Patent Number: GB2356413
Proprietor(s): John Reid & Sons (Strucsteel) Ltd
Inventor(s): John R Reid

This is to Certify that, in accordance with the Patents Act 1977,

a Patent has been granted to the proprietor(s) for an invention entitled
**"Method and apparatus for constructing buildings using braced tied
portals"** disclosed in an application filed **17 November 2000**.

Dated 27 February 2002



Alison Brimelow
*Comptroller General of Patents,
Designs and Trade Marks*
UNITED KINGDOM PATENT OFFICE

The attention of the proprietor(s) is drawn to the important notes overleaf.



ΟΡΓΑΝΙΣΜΟΣ ΒΙΟΜΗΧΑΝΙΚΗΣ ΙΔΙΟΚΤΗΣΙΑΣ

ΔΙΠΛΩΜΑ ΕΥΡΕΣΙΤΕΧΝΙΑΣ

Αριθμ. 1004577

Εχοντας υπόψη :

- α) το άρθρο 8 παρ. 11 του νόμου 1733/87 "Μεταφορά τεχνολογίας, εφευρέσεις, τεχνολογική καινοτομία και σύσταση Επιτροπής Ατομικής Ενέργειας"
- β) την υπ' αρ. 15928/ΕΦΑ/1253 απόφαση του Υπουργού Βιομηχανίας, Ενέργειας και Τεχνολογίας "Κατάθεση αίτησης για χορήγηση Διπλώματος Ευρεσιτεχνίας ή Πιστοποιητικού Υποδείγματος Χρησιμότητας στον ΟΒΙ και τήρηση βιβλίων"
- γ) την αίτηση που κατέθεσε ο ενδιαφερόμενος στον Ο.Β.Ι. στις 29-1-2003 με αριθμό 20030100045 .

Απονέμουμε

Δίπλωμα Ευρεσιτεχνίας με θεωρημένα όλα τα κατά νόμον επισυναπτόμενα σχετικά έγγραφα , στην εταιρία :

ΛΦΟΙ ΧΑΤΖΗΚΩΣΤΗ Ο.Ε. με διακριτικό τίτλο «AGROPLAST»
ΑΘΥΡΑ, 58005 ΠΕΛΛΑ (ΠΕΛΛΗΣ)

ΤΙΤΛΟΣ : " ΠΛΑΣΤΙΚΑ ΦΥΛΛΑ ΑΓΡΟΤΙΚΗΣ ΧΡΗΣΗΣ "

Ο Δ.Ε. 1004577 ΕΙΝΑΙ ΔΙΠΛΩΜΑ ΤΡΟΠΟΠΟΙΗΣΗΣ ΣΤΟ Δ.Ε. 1003939 / 12-3-2001

ΕΥΡΕΤΗΣ(ΕΣ) : ΧΑΤΖΗΚΩΣΤΗΣ ΧΡΗΣΤΟΣ

ΚΛΑΣΗΣ ΤΑΞΙΝΟΜΗΣΗ (INT.CL⁷) : A01G 1/02, A01G 13/02, .

Δίπλωμα Ευρεσιτεχνίας αυτό, ισχύει μέχρι : 13-3-2021

Αθήνα 26/05/2004

Ο Γενικός Διευθυντής



UF GRUND DER ANGEHEFTETEN BESCHREIBUNG UND ZEICHNUNG IST DURCH BESCHLUSS DES KAISERLICHEN PATENTAMTES

an Rudolf Diesel, Ingenieur,
in Berlin

EIN PATENT ERTHEILT WORDEN.

GEGENSTAND DES PATENTES IST:

GESETZ v. 7. APRIL 1891

Arbeitsverfahren und Ausführungsart für
Verbrennungskraftmaschinen.

ANFANG DES PATENTES: 28. Februar 1892.

DIE RECHTE UND PFLICHTEN DES PATENTINHABERS SIND DURCH DAS PATENTGESETZ VOM 7. APRIL 1891 (REICHS-GESETZBLATT FÜR 1891 SEITE 79) BESTIMMT.

ZU URKUND DER ERTHEILUNG DES PATENTES IST DIESE AUSFERTIGUNG ERFOLGT.

Berlin, den 23. Februar 1893.

KAISERLICHES PATENTAMT.

Beglaubigt durch *Frank*

Bureau-Vorsteher des Kaiserlichen Patentamtes.



Two are the main reasons for instituting patents. One is to **provide incentives** for individuals and companies to engage in research and develop new products; in other words, the **promotion of innovation**. The expectation of profitable exploitation of the exclusive right encourages individuals and companies to turn their activities to innovative products, which society will later benefit from.

The second reason is the **publication of innovations**. If patents didn't exist, inventors would try to keep their inventions secret so that competitors wouldn't copy them. In this way, we have a trade between the inventor and society: the inventor reveals his innovation and society gives him the right to exploit it exclusively for the next 20 years.

Myth #1: patents provide incentives which promote innovation

Myth #2: Being publicly accessible descriptions of innovations, patents promote the diffusion of knowledge and so further innovation

Myth {1}

Thesis: Patents have a positive effect on innovation and productivity.

Justification: technology is knowledge and knowledge is a public good, therefore investment in technology and its production will be insufficient unless it can be ensured that the inventor will profit from his investment...for this reason, mechanisms of exclusion (i.e. patents, copyrights) are created to prohibit the reproduction of the good, thereby creating an artificial scarcity (Arrow 1962).

Empirical proof: “the patent puzzle”

The US Patent Office granted in year:

1983: 59.715 patents

2003: 189.597 >>

2010: 244.341 >>

→ *In 30 years the flow of patents has quadrupled.*

However, according to the US Bureau of Labor Statistics, the annual growth in productivity in the decade 1970-1979 was about 1,2%, while in the next two decades it fell below 1%. In the same period, R&D expenditure has been around 2,5% of GDP.

Conclusion

“there is no empirical evidence that they serve to increase innovation and productivity, unless productivity [and innovation] is identified with the number of patents awarded” (Boldrin & Levine 2013, p. 3)

Myth {2}

Patents, insofar as they replace socially harmful trade secrets, encourage the diffusion of ideas, thereby promoting innovation

In reality however...

“Companies typically instruct their engineers developing products to avoid studying existing patents so as to be spared subsequent claims of willful infringement, which raises the possibility of having to pay triple damages” (Boldrin & Levine 2013,p.9)

As Eric Brec (2008), Microsoft programmer, explains:

“[Microsoft policy is for developers to] never search, view, or speculate about patents. I was confused by this guidance till I wrote and reviewed one of my own patents. The legal claims section—the only section that counts—was indecipherable by anyone but a patent attorney. Ignorance is bliss and strongly recommended when it comes to patents”.

On the contrary, what promotes innovation is the truly free communication of ideas and knowledges, based on collaboration, transparency, open access, open standards, open source, institutional regimes of the kind epitomised by open science...

Examples: a) Cornish steam engine b) the making of the personal computer at the Homebrew Computer Club and c) RepRap 3D printer

Cornish steam engine (1772-1852)



Cornish Beam Engine built in Cornwall, England ~1830. Powered an ore crushing mill and de-watered a mine. Used at the Vacluse Mine near Fredricksburg, Virginia

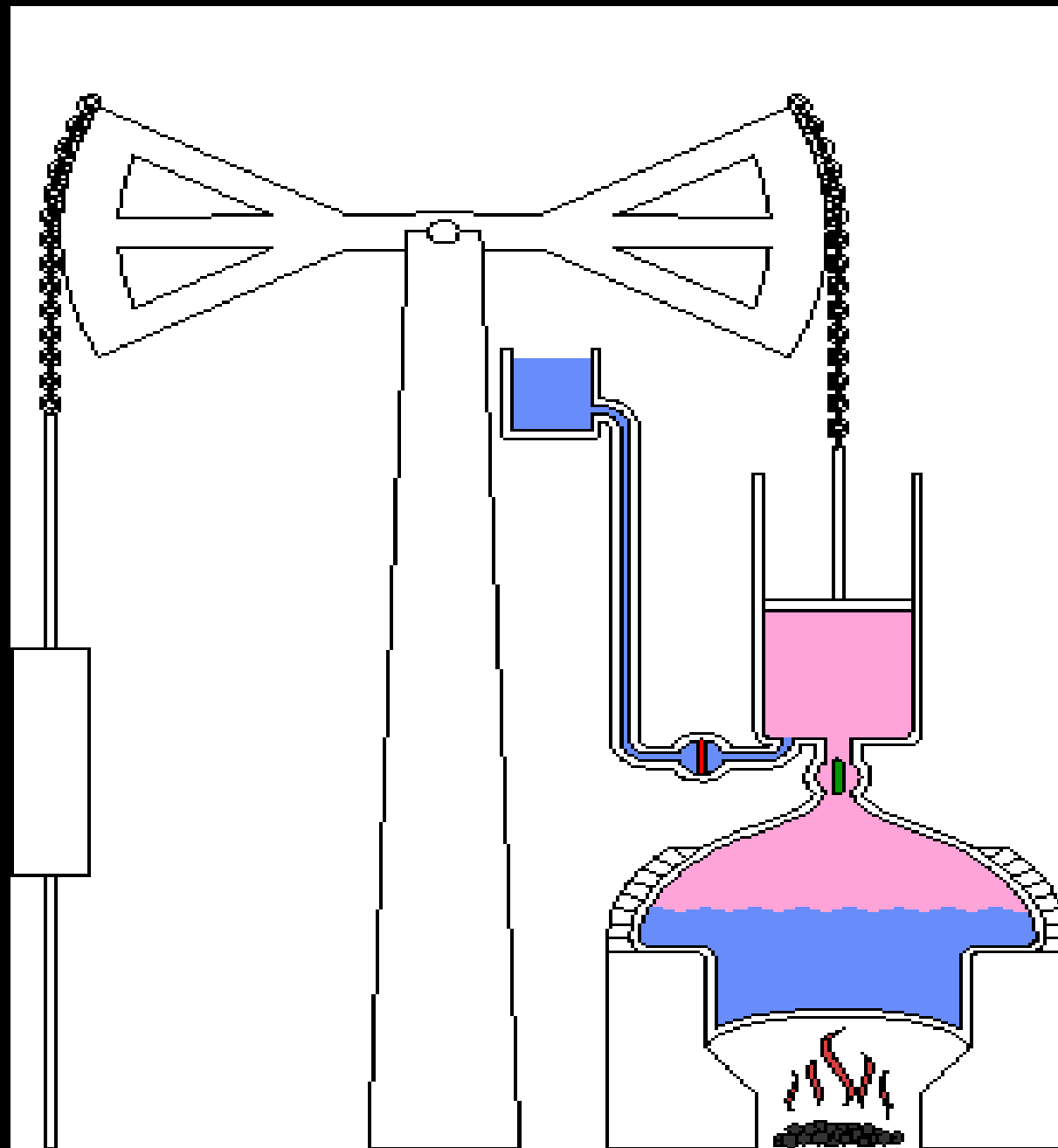

- Steam is shown pink and water is blue.
- Valves move from open (green) to closed (red)

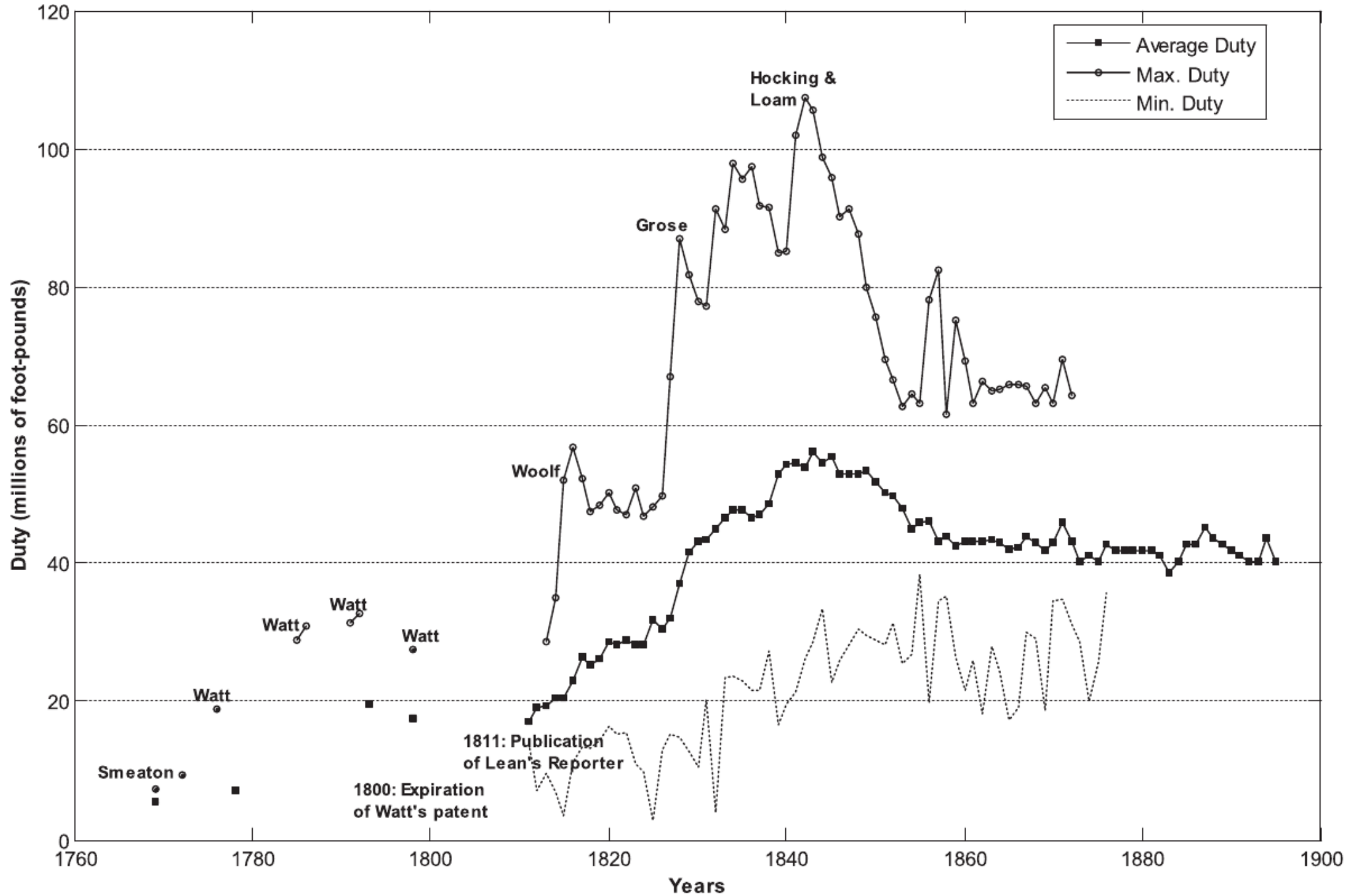

Source: A. Nuvolari (2004) *The Making of Steam Power Technology: A Study of Technical Change during the British Industrial Revolution*. PhD Dissertation, Eindhoven University of Technology

1769-1800: 18M–30M (*31 yrs of Watt's patent*)

1786-1800: no increase in the duty of steam engines at all

1801-1852: 30M–110M (*after Watt's patent expired*)

1811: Lean's Engine Reporter

Cornish engineers published details of their engines ('open design commons') and freely shared improvements...

...like free/open source software developers do it today

RepRap



Source: <https://www.youtube.com/watch?v=NX46AXfkbs0>

3D printers have been used in the manufacturing industry for 40 years, but until recently 3D printing was a patented technology



US005121329A

United States Patent [19]

[11] Patent Number: 5,121,329

[45] Date of Patent: Jun. 9, 1992

Crump

[54] APPARATUS AND METHOD FOR CREATING THREE-DIMENSIONAL OBJECTS

[75] Inventor: S. Scott Crump, Minnetonka, Minn.

[73] Assignee: Stratasys, Inc., Minneapolis, Minn.

[21] Appl. No.: 429,012

[22] Filed: Oct. 30, 1989

[51] Int. Cl.⁵ G06F 15/46

[52] U.S. Cl. 364/468; 364/474.24; 364/477; 264/239; 264/25; 425/174.4

[58] Field of Search 364/472, 473, 477; 264/308, 113; 425/174.4; 427/8, 52; 164/94; 239/75, 82, 83, 84, 132

[56] References Cited

U.S. PATENT DOCUMENTS

1,934,891	11/1933	Taylor	239/83
3,749,149	7/1973	Paton et al.	164/94
4,071,944	2/1978	Chuss et al.	427/8
4,247,508	1/1981	Housholder	264/221
4,293,513	10/1981	Langley et al.	264/308
4,545,529	10/1985	Tropecano et al.	239/75
4,575,330	3/1986	Hull	364/473
4,595,816	6/1986	Hall et al.	364/477
4,665,492	5/1987	Masters	364/474.02
4,681,258	7/1987	Jenkins et al.	239/83
4,863,538	9/1989	Deckard	
4,938,816	7/1990	Beaman et al.	
4,944,817	7/1990	Bourell et al.	

OTHER PUBLICATIONS

Article entitled "Instant Gratification", *High Technology Business* Author-Gregory T. Pope-Jun. 1989.

Asymtek Brochure, "Benchtop Automation" May 1988.

Primary Examiner—Joseph Ruggiero
Assistant Examiner—Patrick D. Muir
Attorney, Agent, or Firm—Moore & Hansen

[57] ABSTRACT

Apparatus incorporating a movable dispensing head provided with a supply of material which solidifies at a predetermined temperature, and a base member, which are moved relative to each other along "X," "Y," and "Z" axes in a predetermined pattern to create three-dimensional objects by building up material discharged from the dispensing head onto the base member at a controlled rate. The apparatus is preferably computer driven in a process utilizing computer aided design (CAD) and computer-aided (CAM) software to generate drive signals for controlled movement of the dispensing head and base member as material is being dispensed.

Three-dimensional objects may be produced by depositing repeated layers of solidifying material until the shape is formed. Any material, such as self-hardening waxes, thermoplastic resins, molten metals, two-part epoxies, foaming plastics, and glass, which adheres to the previous layer with an adequate bond upon solidification, may be utilized. Each layer base is defined by the previous layer, and each layer thickness is defined and closely controlled by the height at which the tip of the dispensing head is positioned above the preceding layer.

44 Claims, 3 Drawing Sheets

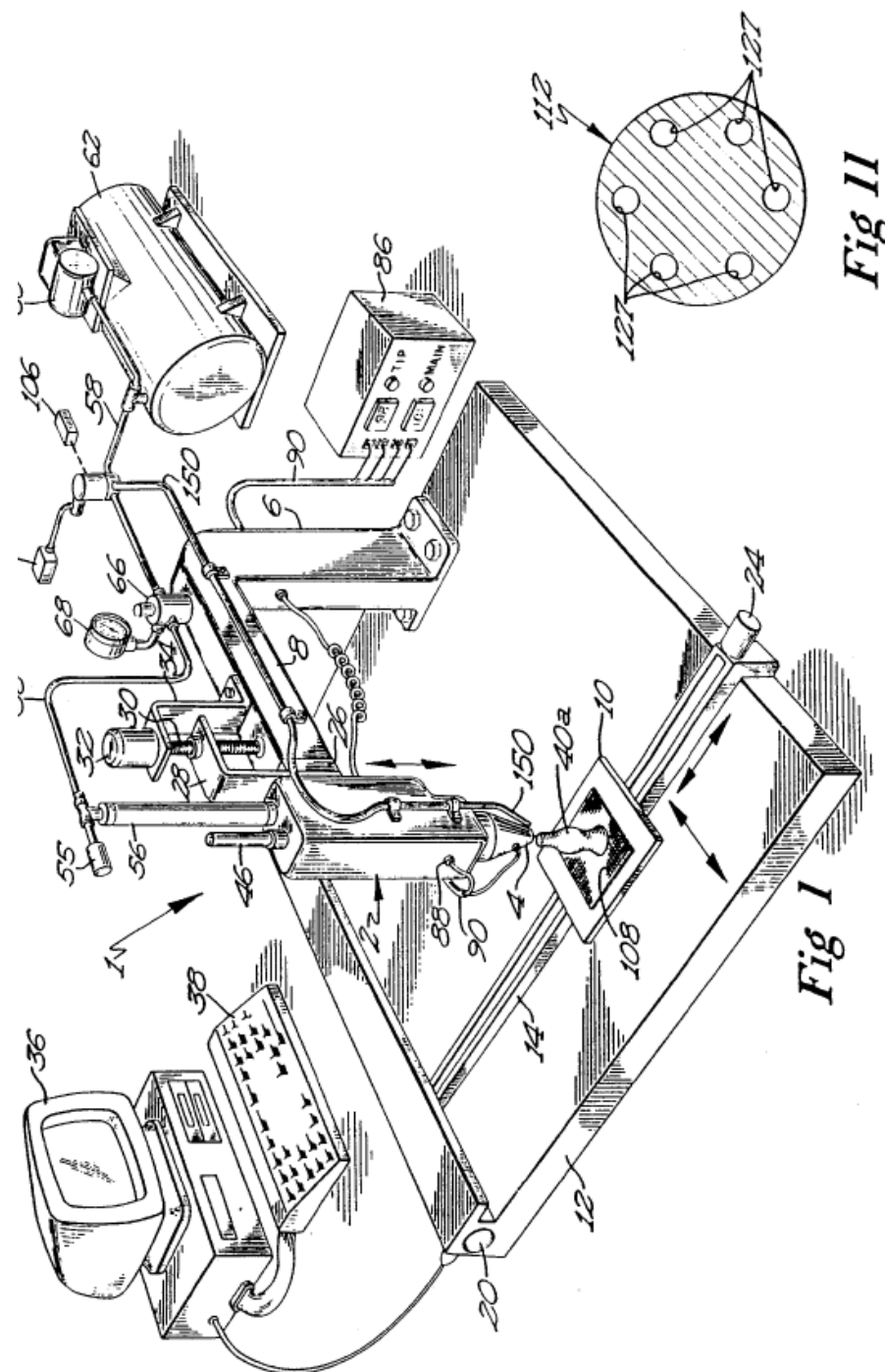
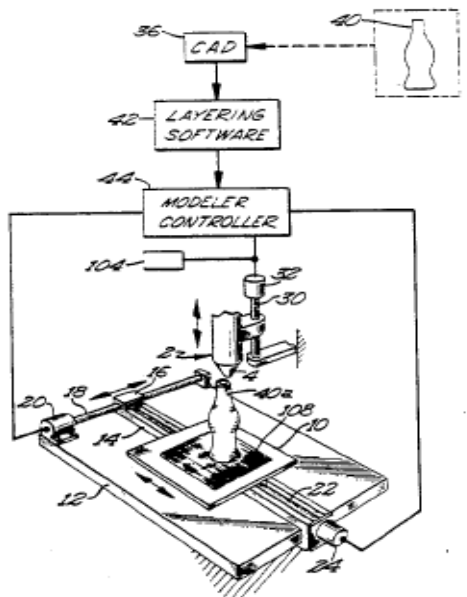

Fig I

Fig II

in the mid-2000s the expiration of a set of patents related to 3D printing triggered the emergence of the open source 3D printing movement, which coalesced around the RepRap project

"If people can make anything for themselves what's the point in going to the shops?"

(Dr Adrian Bowyer, founder of RepRap project, quoted in The Guardian, Nov. 2006)

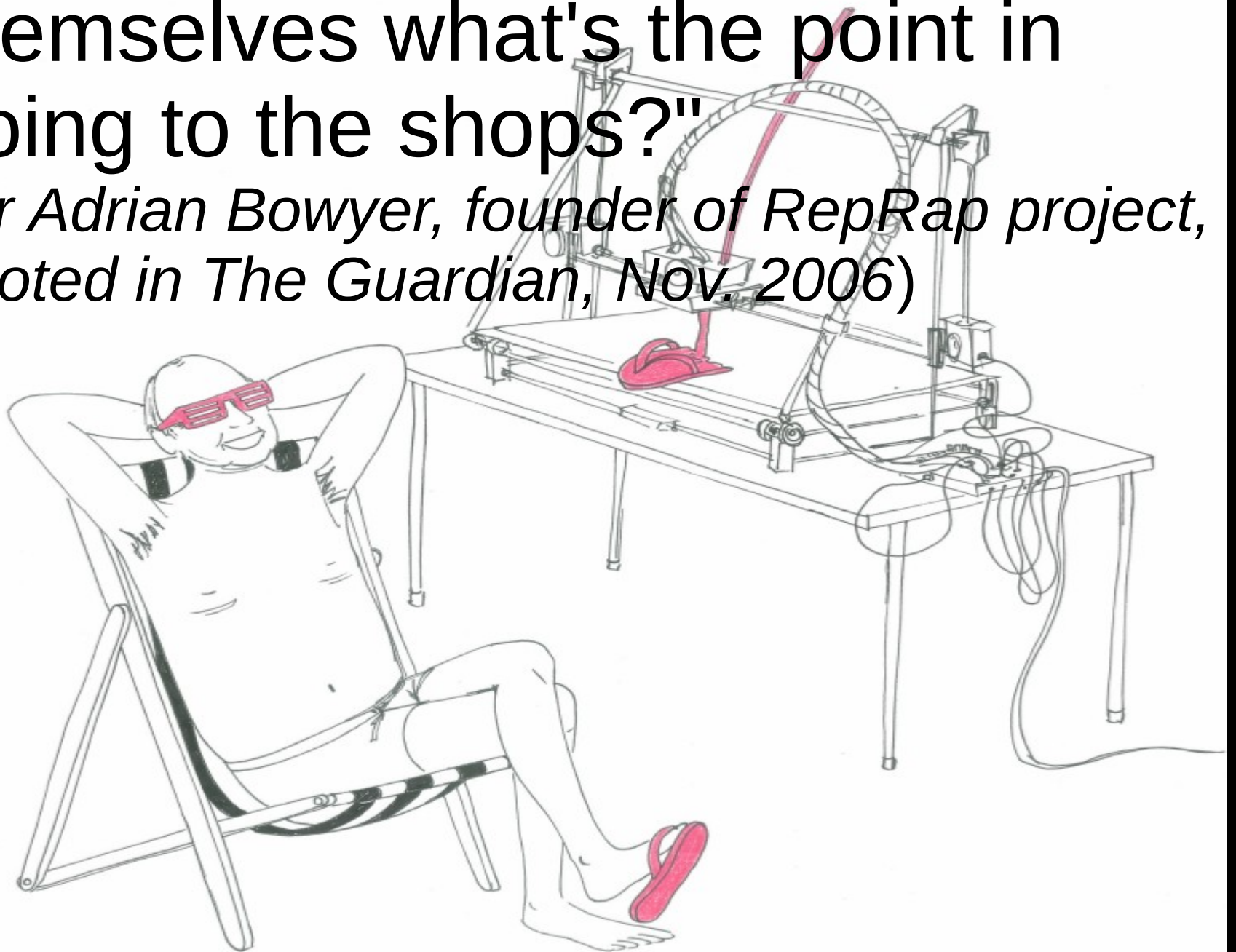

RepRap 3D printer project

- Started in 2005 by Dr Adrian Bowyer at Bath University
- By 2010, it had evolved in a global network of about 5,000 contributors (and community size is doubling every six months) which improved RepRap's design and performance, made it cheaper to build and led to a proliferation in the kinds of objects people use it for

RepRap operators



<http://maps.google.com/maps/ms?ie=UTF8&hl=en&msa=0&msid=117099291054388532447.0004409098b1c5b712553>

Rep Rap v. 1 ('Darwin'), May 2007

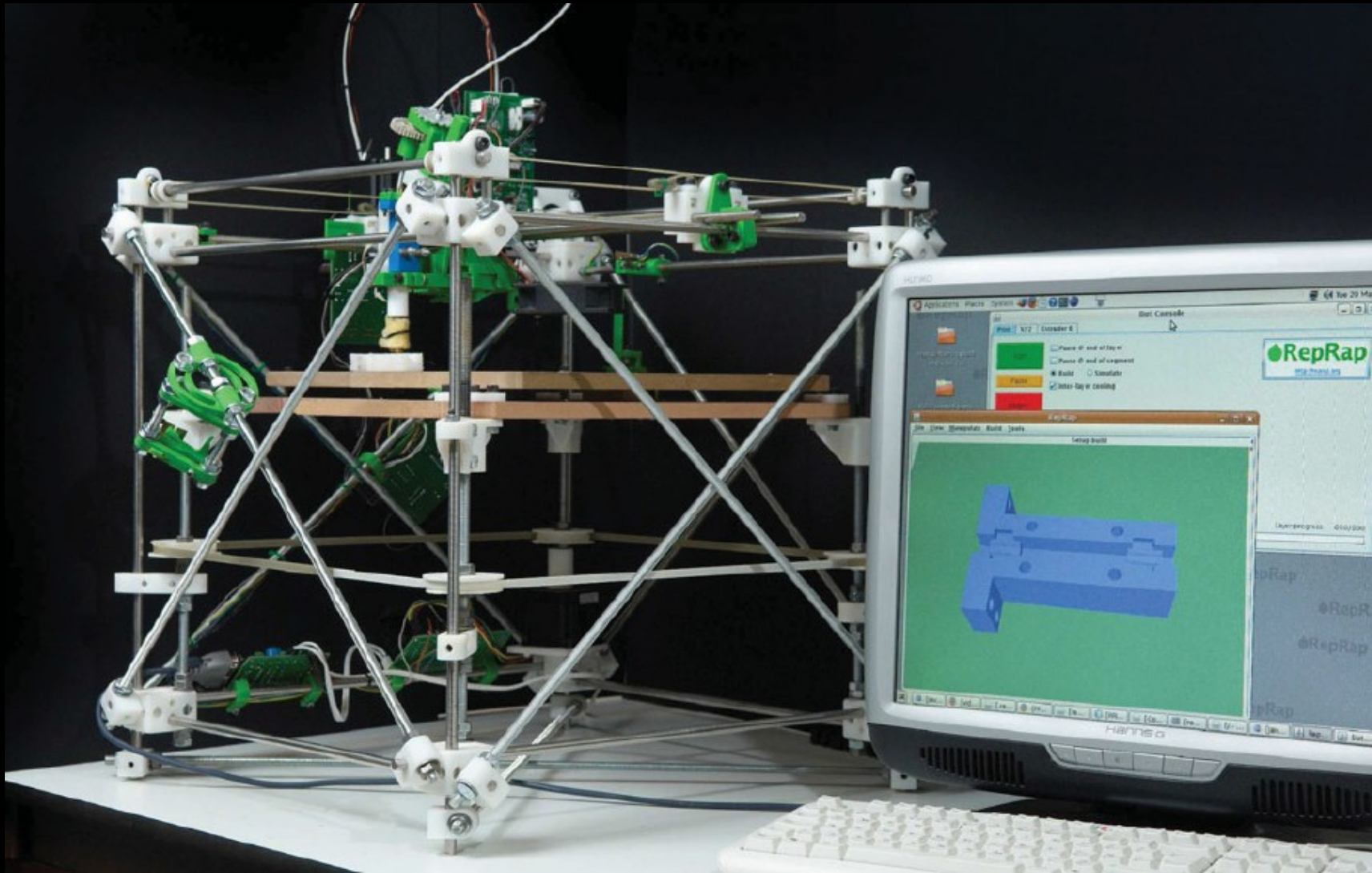

Source:<http://203.96.60.151/bin/view/Main/PressPix?skin=print.pattern>

It can be used to make things like...



Rep Rap v. 2 ('Mendel'), 2009

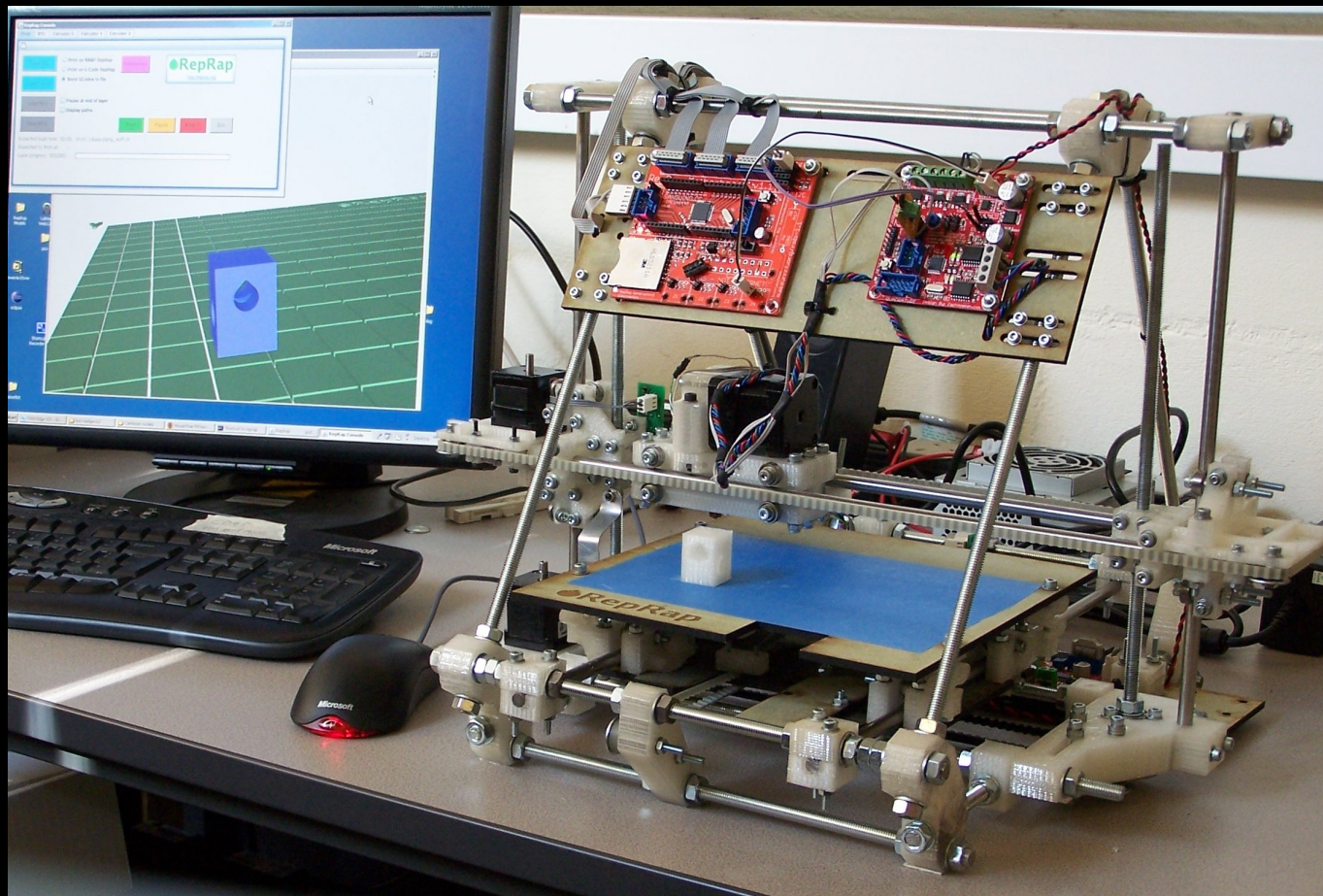

Source: https://en.wikipedia.org/wiki/RepRap_Project

Experimentation with design parameters: Mini-Mendel



RepRap v. 3 ('Huxley'), 2010

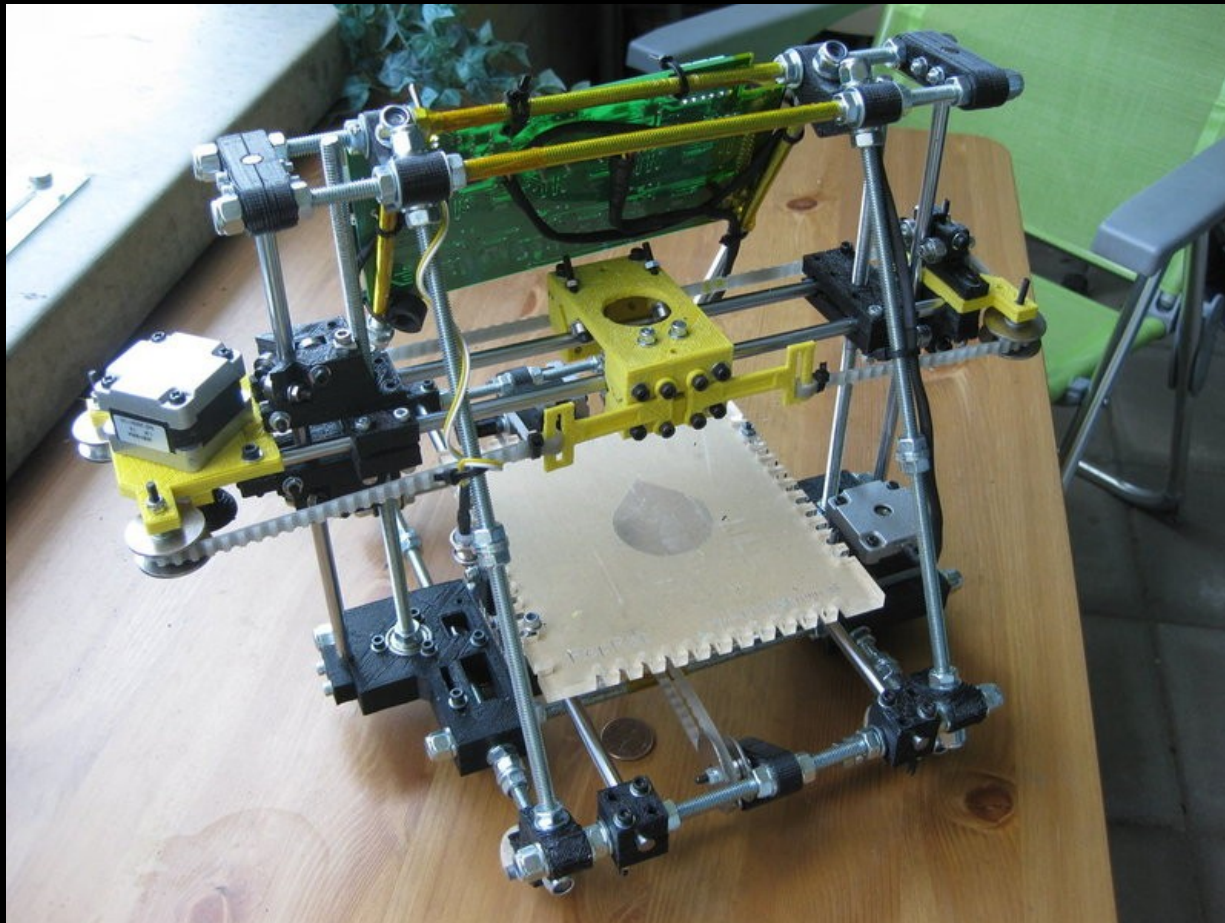

Source: <http://reprap.org/wiki/Huxley>

Some people even built one with
lego parts

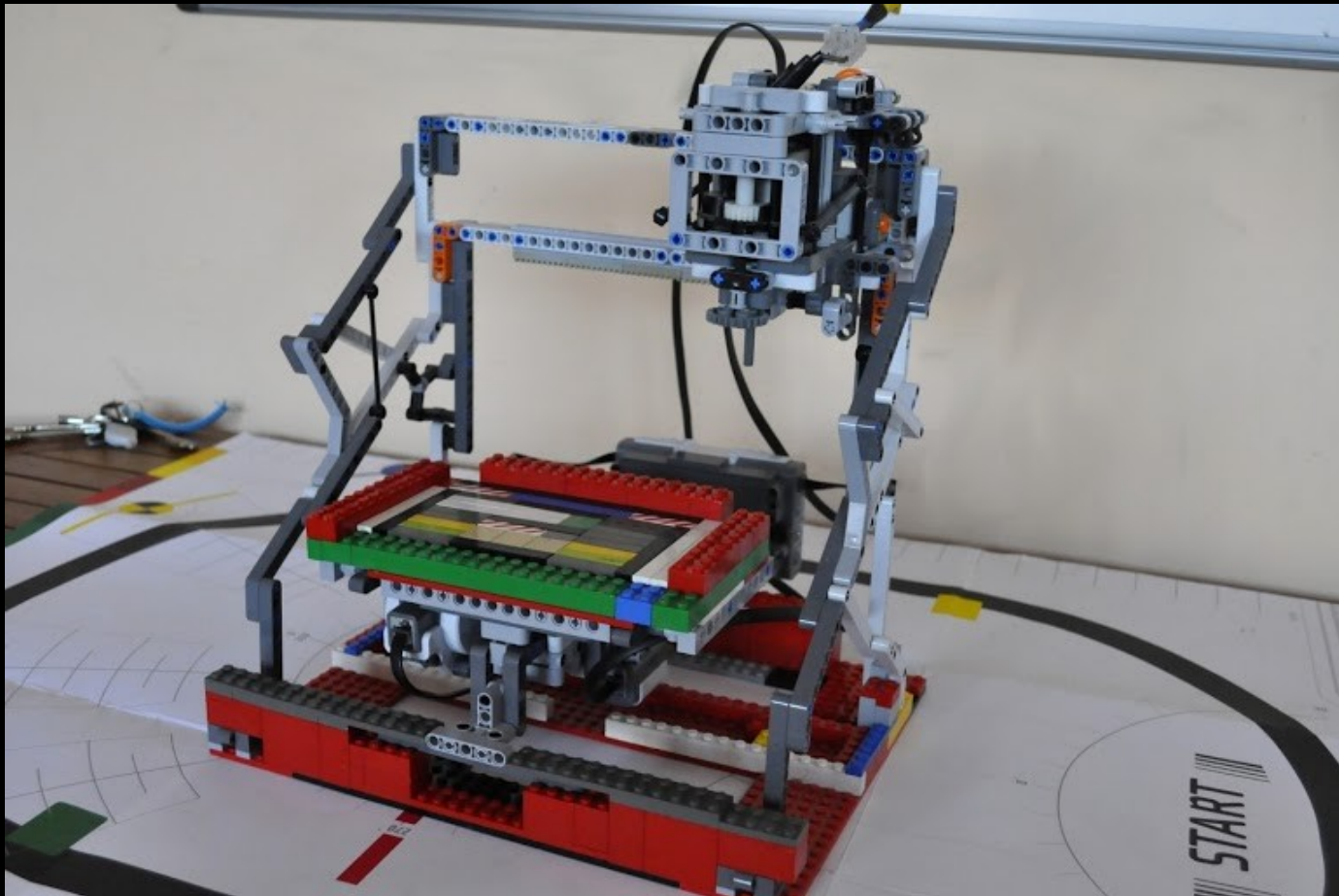

Source: <http://p2plab.gr/en/archives/163>

How can a company compete against a community of thousands?



Stratasys (50 employees)
low-end 3D printer \$25-40K



Rep-rap kit \$875
(Makerbot)

Stratasys is a 3D printing company co-founded by Scott Crump, who was granted in 1992 a key patent for 3D printing. The patent expired in 2009. MakerBot Industries was founded in the same year.

It can be used to make things like...



...clothes



July 2010: Amsterdam
International Fashion Week
(Iris van Herpen/Daniel Widrig)



Jan. 2013: Paris Fashion Week
(Iris van Herpen's Haute Couture
show, 'VOLTAGE')

...a Helix-T wind turbine

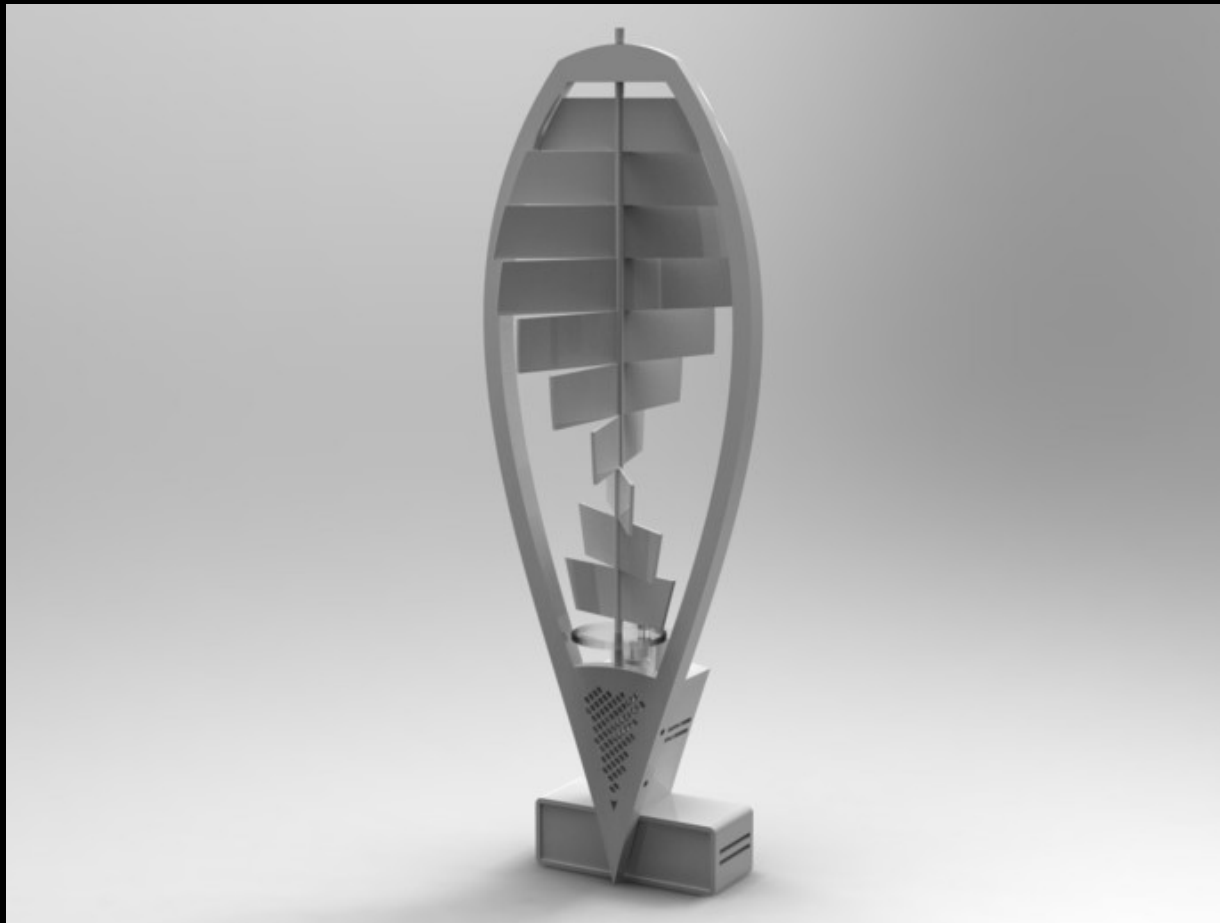

Source: <http://p2plab.gr/en/archives/38>

...prosthetic legs



Source: <http://i.materialise.com/blog/entry/2010-the-year-in-3d-printing>

...wearable mobile phones



Source: <http://www.instructables.com/id/Making-Glove-One-a-3D-printed-wearable-cell-p/>

...even guns



Source: http://funwithelectrons.blogspot.gr/2011_08_01_archive.html

“A once-shuttered warehouse is now a state-of-the art lab where new workers are mastering the 3-D printing that has the potential to revolutionize the way we make almost everything” (B. Obama, US President's State of the Union address, 2013)

Enabling mechanisms

- *Open licensing* (GNU GPL) → open source hardware means that design information is publicly shared
 - ...so that anyone can study it, use it or modify it to make their own 3D printers and redistribute them (with or without a fee is irrelevant as long as design information is universally accessible)
 - Reinforces dynamics of collaboration (because it offers protection against the danger of private expropriation and commercial co-optation)

Patents: so, why and how do companies use them?

- a) Patents are used as means to signal the value of the company to potential investors
- b)...as means to prevent market-entry by other companies: that is, they have *strategic* value independently of whether they are incorporated in profitable products
- c)...as weapons in an 'arms-race': they are used *defensively* to prevent or blunt legal attacks from other companies

The case of Microsoft and Motorola Mobility

Microsoft is using a patent (no. 6370566) for the scheduling of meetings in order to impose a licensing fee on Android mobile phones.

That is, patents become a mechanism for sharing the profits without any participation in the process of innovation. Thus, they discourage innovation and constitute a pure waste for society.

Ironically, not that long ago Bill Gates (1991)
argued that...

“If people had understood how patents would be granted when most of today's ideas were invented, and had taken out patents, the industry would be at a complete standstill today...A future startup with no patents of its own will be forced to pay whatever price the giants choose to impose”.

“In the long run...patents reduce the incentives for current innovation because current innovators are subject to constant legal action and licensing demands from earlier patent holders” (Boldrin & Levine 2013, p.7)

This becomes readily understood, considering that innovation is *cumulative*: cumulative technologies are those in which every innovation builds on preceding ones: e.g. the steam engine, but also hybrid cars, Facebook...

Then, what accounts for the increase in patents and the expansion of the relevant laws?

Political influence of large, cash-rich companies unable to keep up with new and creative competitors (Boldrin & Levine 2013)

Thank you

Email: georgedafermos@gmail.com

bibliography

Boldrin & Levine (2013) 'The case against patents'. *Journal of Economic Perspectives* 27(1): 3-22

Dosi, Marengo & Pasquali (2006) 'How much should society fuel the greed of innovators?' *Research Policy* 35: 1110-1121

And the references included in the above papers.